

SHIMANO Caliper Brake

new



Auto Adjust

Model BB-210
TOURNEY

SPECIFICATIONS
Material: Light Alloy
Type: Caliper Brake
Side Pull

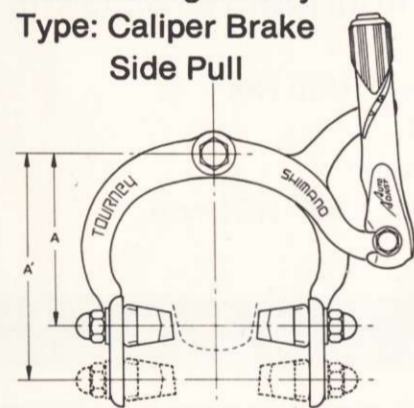

Type	A-A'	Weight (Pair)
CS-72A	54mm — 72mm	11.5 oz. (325 g)
CS-79A	61mm — 79mm	11.8 oz. (335 g)
CS-88A	70mm — 88mm	12.2 oz. (345 g)

Model BB-110
TOURNEY

SPECIFICATIONS
Material: Light Alloy
Type: Caliper Brake Center Pull

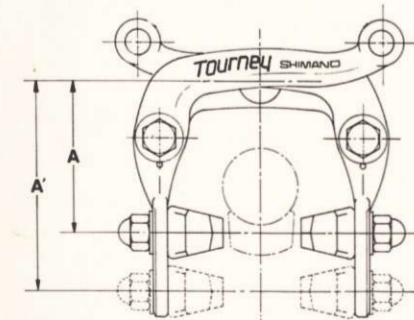

Type	A-A'	Weight (Pair)
CC-65A	47mm — 65mm	18.2 oz. (515 g)
CC-75A	57mm — 75mm	18.5 oz. (525 g)

The AUTO ADJUST is designed to execute the automatic compensation of the rim-brake shoe clearances which change as brake shoes are worn or the brake wire is

stretched. With the AUTO ADJUST, an optimum gap can always be maintained between the brake lever and the handle bar. As a result, greater riding safety is insured.

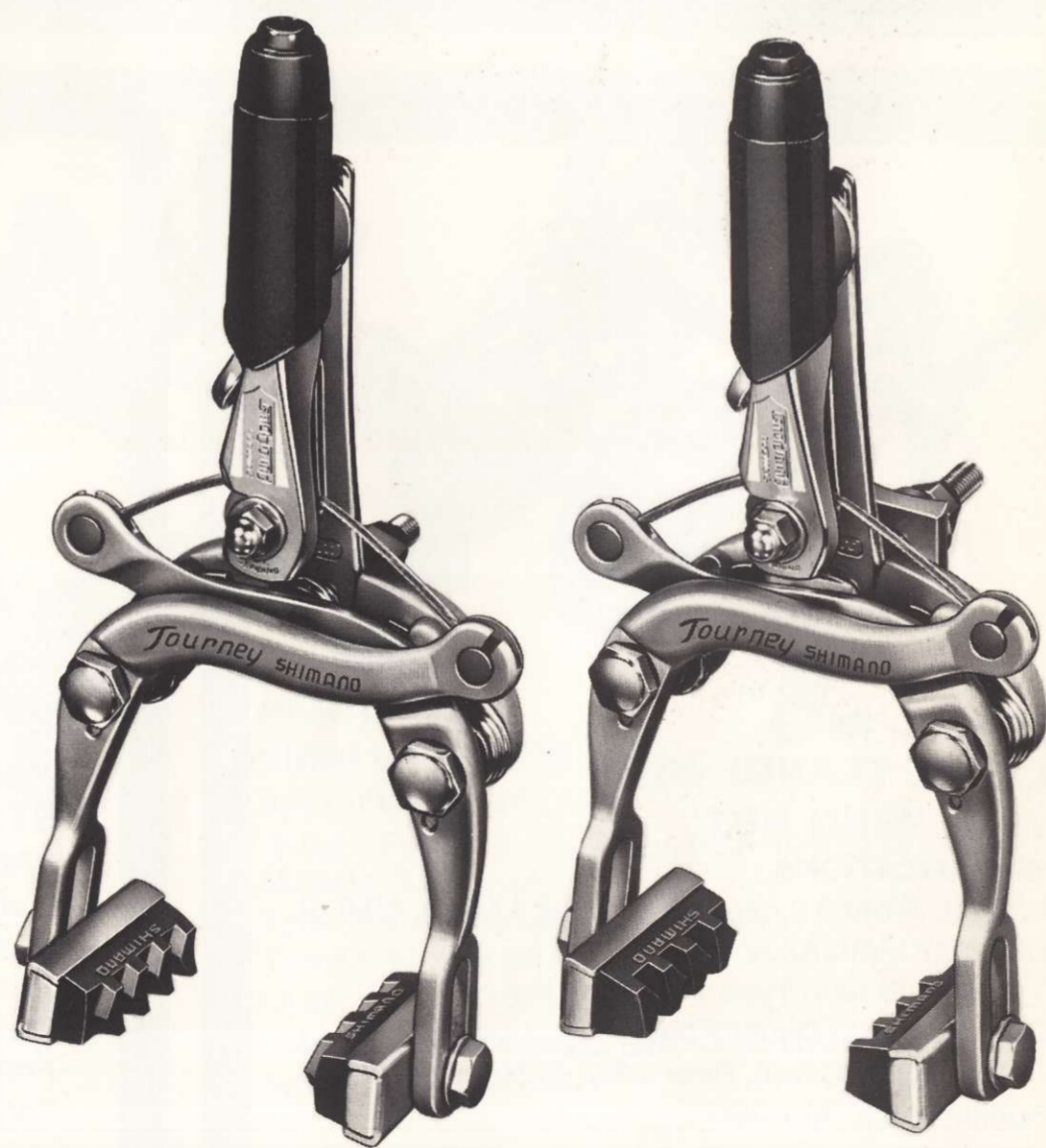
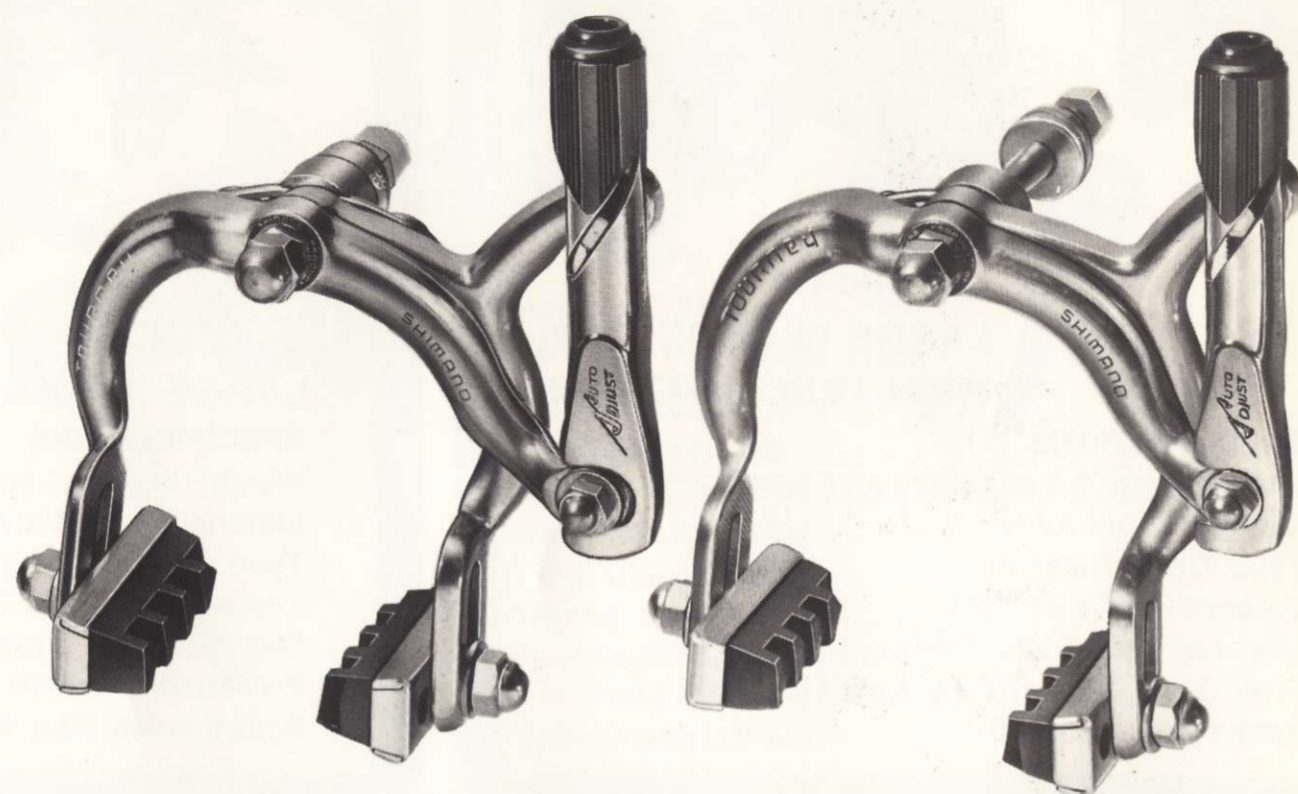

Caliper Brake

Model BB-200
TOURNEY

SPECIFICATIONS
Material: Light Alloy
Type: Caliper Brake
Side Pull

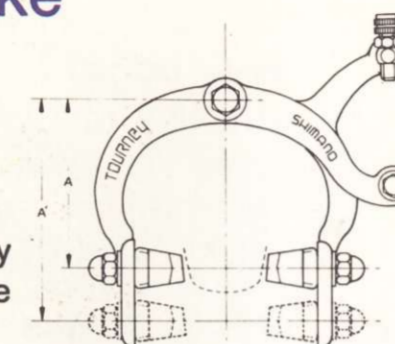

Type	A-A'	Weight (Pair)
CS-72	54mm — 72mm	10.1 oz. (285 g)
CS-79	61mm — 79mm	10.4 oz. (295 g)
CS-82	70mm — 88mm	10.8 oz. (305 g)

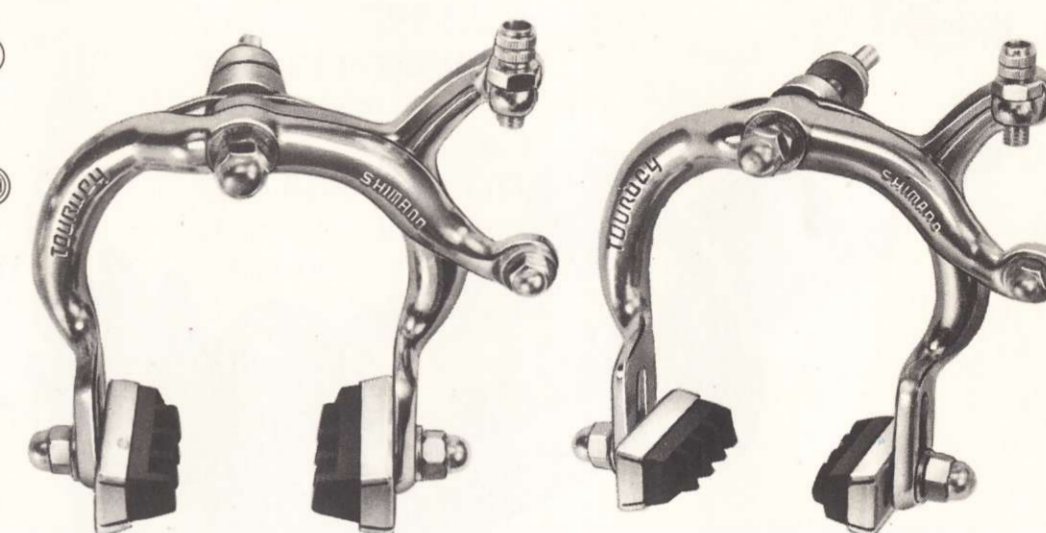

Model BB-100
TOURNEY

SPECIFICATIONS
Material: Light Alloy
Type: Caliper Brake
Center Pull

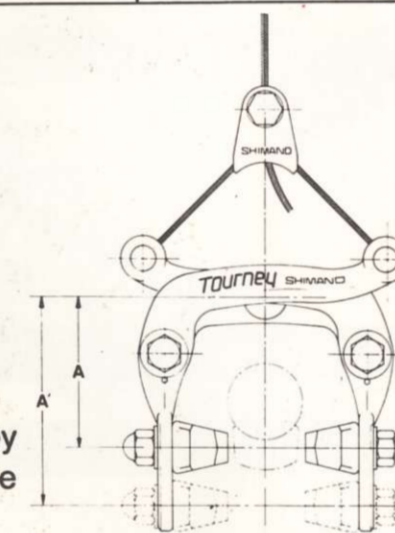

Type	A-A'	Weight (Pair)
CC-65	47mm — 65mm	12.7 oz. (360 g)
CC-75	57mm — 75mm	13.1 oz. (370 g)

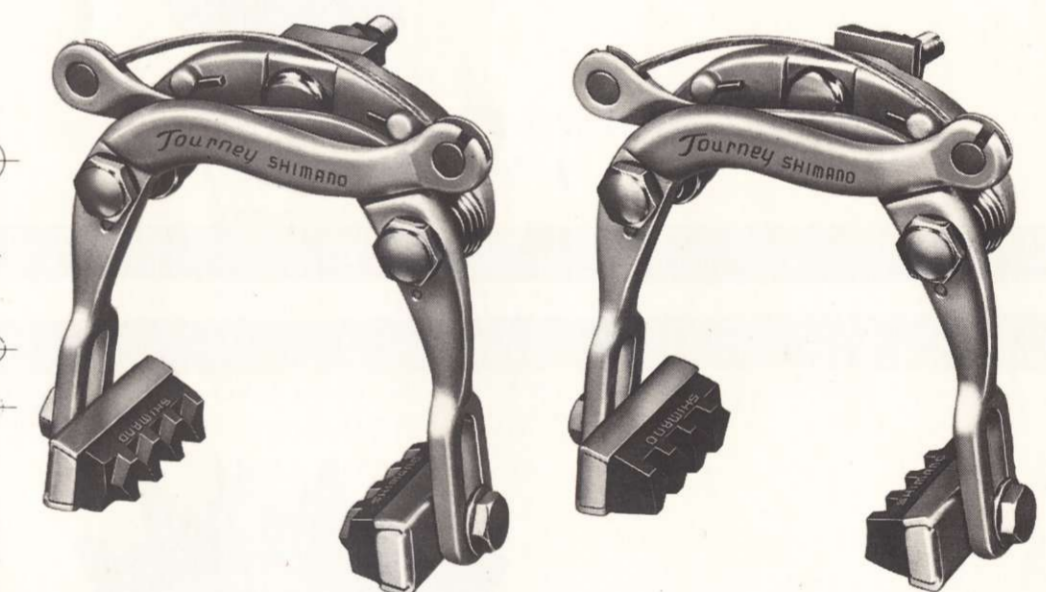

Brake Lever

Model MD-100
POPULAR LEVER

SPECIFICATIONS
Material: Light Alloy
Clamp Diameter: 22.2φ



Model MC-100
TOURIST LEVER

SPECIFICATIONS
Material: Light Alloy
Clamp Diameter: 22.2φ

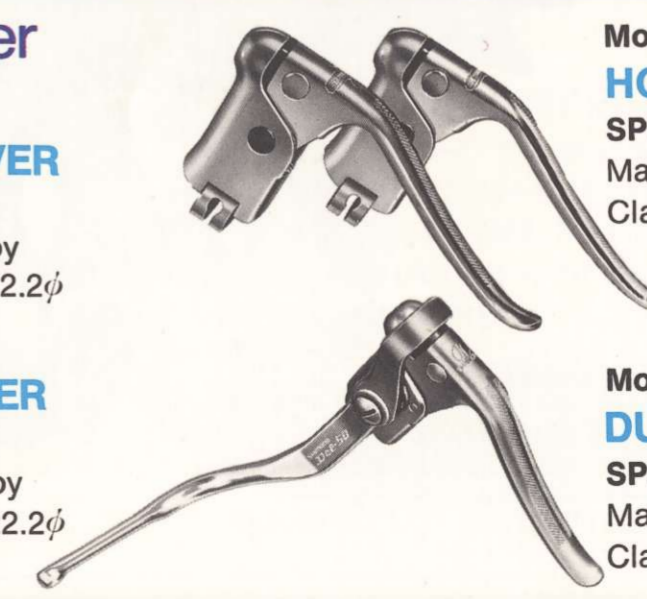

Model MB-100
HOODED LEVER

SPECIFICATIONS
Material: Light Alloy
Clamp Diameter: 22.2φ, 23.8φ

Model MB-110
DUAL EXTENSION LEVER

SPECIFICATIONS
Material: Light Alloy
Clamp Diameter: 22.2φ, 23.8φ