

FRAME TUBE CUT WORK ILLUSTRATION

TOP TUBE

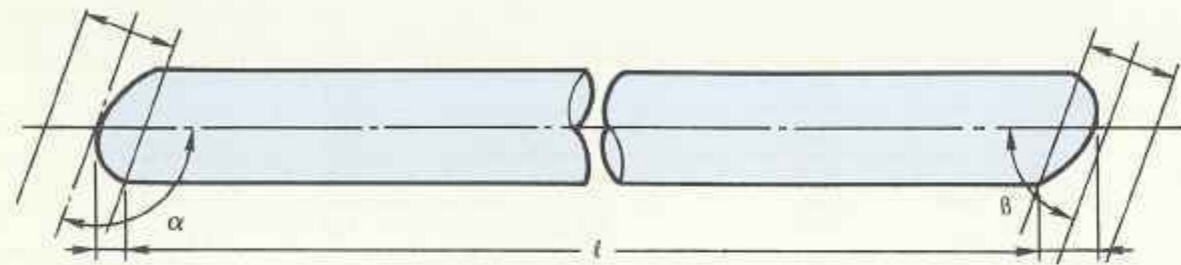

SEAT TUBE

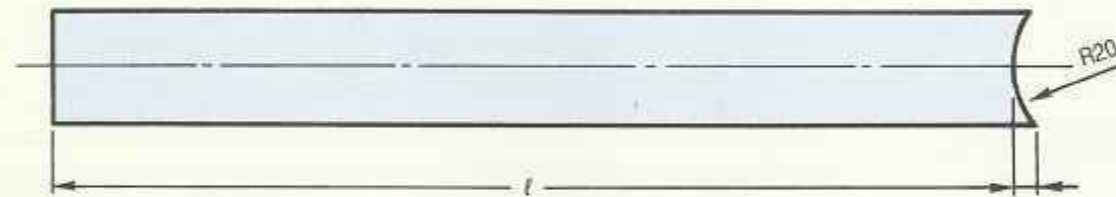

DOWN TUBE

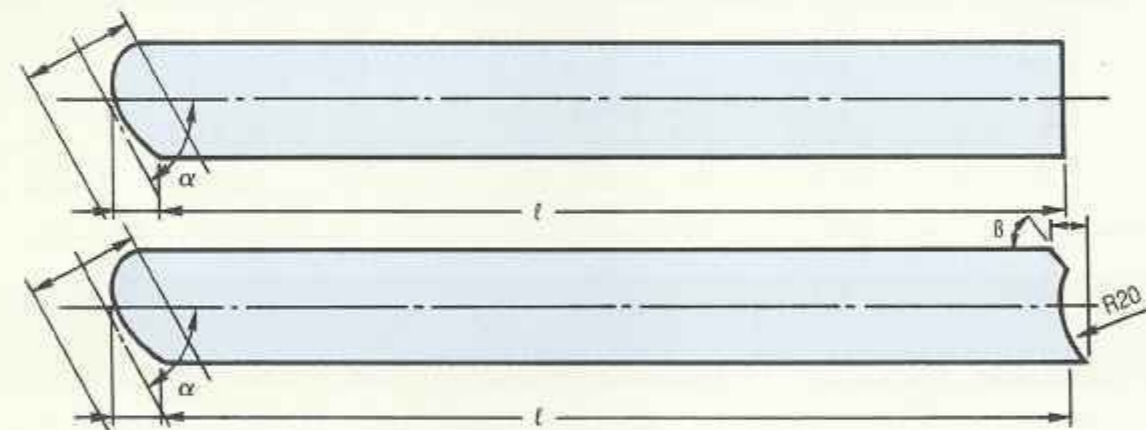

Brazing Cr-Mo Materials

1. When brazing, please use material with expansion strength of 60 km/mm² with a melting point of around 850°C. For flux, use either gas flux or paste flux No. 110. (PRESTIGE)
The melting point of the brazing material should be 650°C to 850°C. Use flux which is suitable to the brazing material used.
2. To ensure smooth brazing flow, it is important to clear away impurities from the parts to be brazed.
3. Before brazing, the tube and minor parts have to be thoroughly polished. For heating, concentrically apply small amounts and soft braze as far as possible.

- Also, take care not to allow overheating.
4. After brazing, cool as slowly as possible.
 5. If brazed section appears to be brittle, heat again at 700°C ~ 900°C and cool slowly.
 6. Take care in cutting the tube: TANGE mark is provided on the end (to be fixed to the Head Tube) of both the Top and Down Tube, and on the end (to be fixed to the B.B. Shell) of the Seat Tube.
Cut the tube on the opposite side of the TANGE MARK.
 7. Take note of the butted section length (l_1 and l'_1) when cutting the tube. (See page 15 ~ 22)

SEAT & CHAIN STAY WORK

SEAT STAY

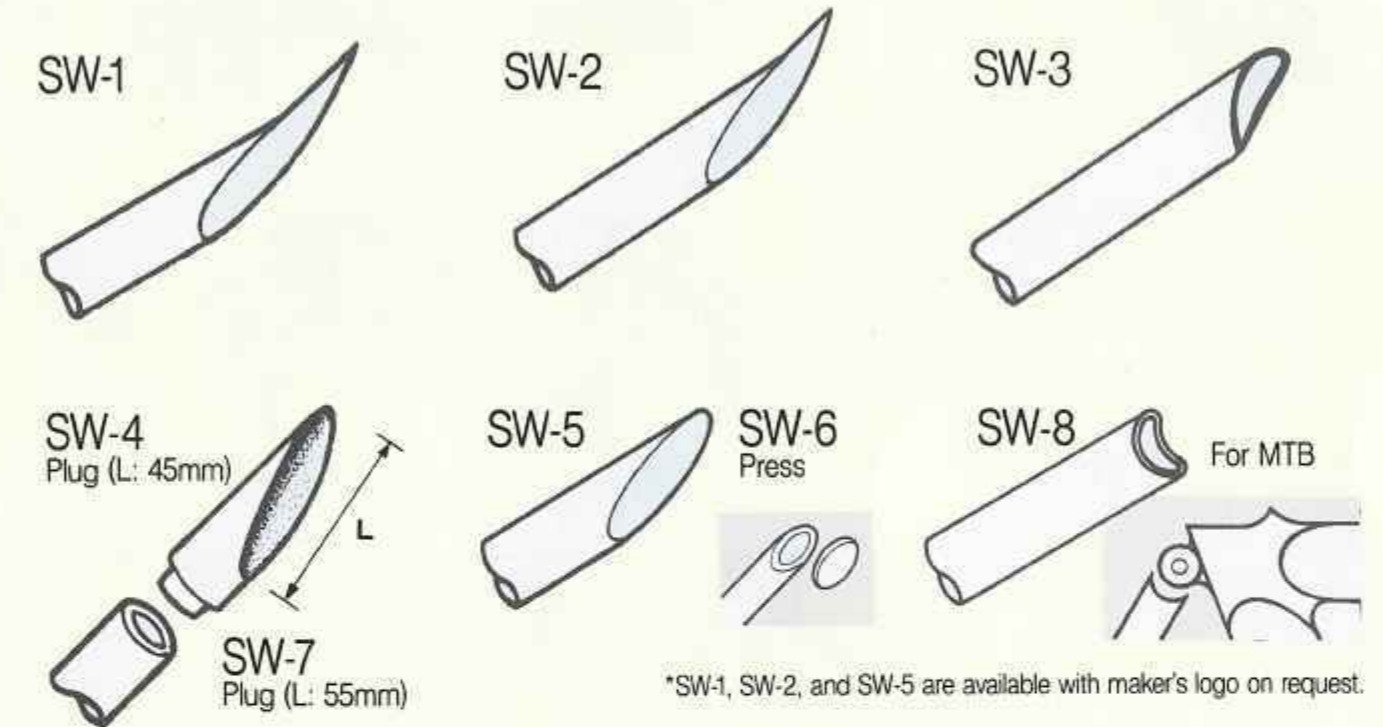

CHAIN STAY

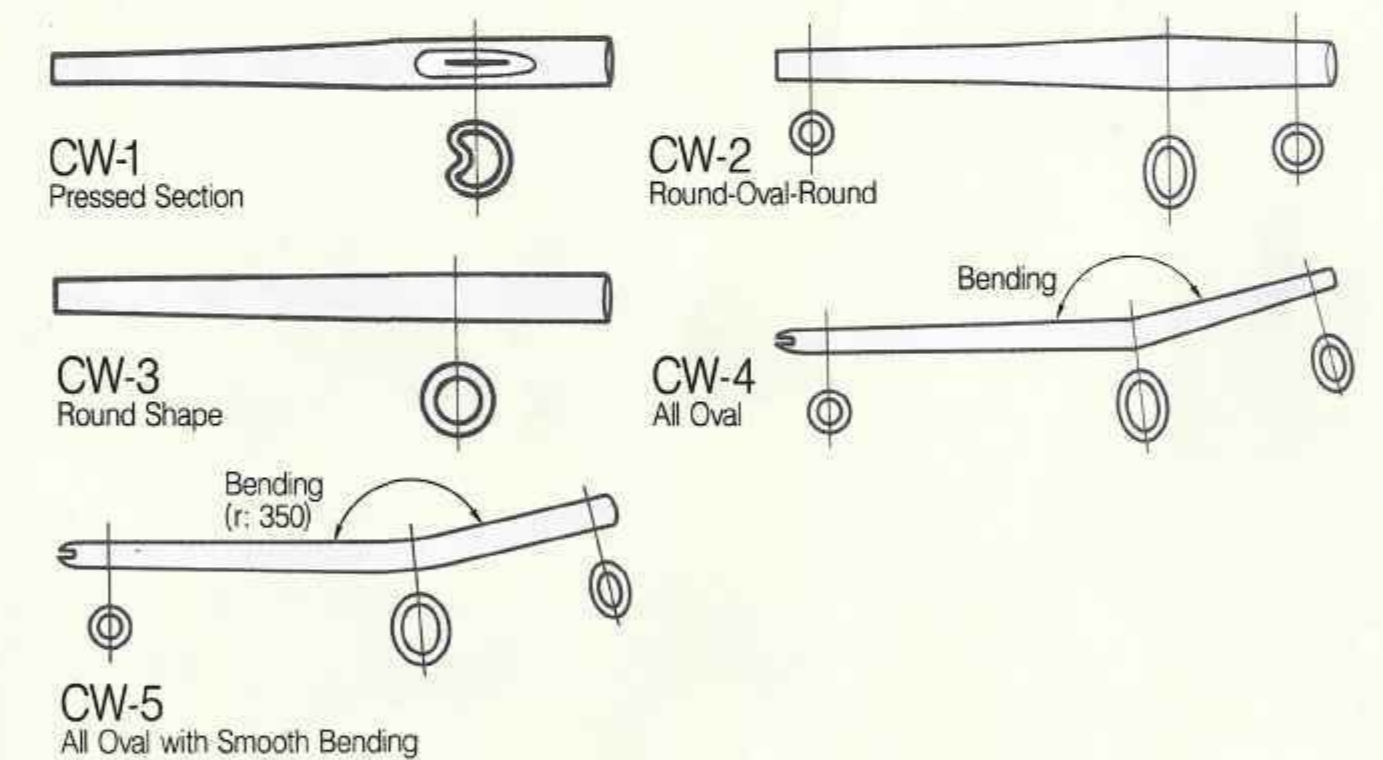

SEAT & CHAIN STAY TIP

